

## Tree Survey, Categorisation & Constraints Report

in accordance with

BS 5837:2012 (Survey Phase 4.4, 4.5 & 4.6)

At

### Caerleon Comprehensive School

On the instructions of

Newport Norse

Dated: June 2024



Inspected by:

Mr. Ben Clark. L4 Dip Arb

Approved by Mr. S J Ambler. Cert.Arb.(RFS), Tech.Arbor.A., Dip.Arb. (RFS), F.ARBOR.A.

Of



Steve Ambler and Sons Tree Specialists Ltd.

Tel/Fax- 01443 862724

Mobile- 07961 322908

Email- Vaughan@steveamblyertrees.com

Web- www.steveamblyertrees.com

Signed Steve Ambler		Signed Ben Clark	
Date	5 <sup>th</sup> July 2024	Date	27/06/2024

## TABLE OF CONTENTS

1. INTRODUCTION .....	3
2. SITE DESCRIPTION AND OBSERVATIONS.....	4
3. SPECIES RECORDED .....	5
4. TREE SURVEY & TREE SURVEY PLAN .....	6
5. TREE CONSTRAINTS PLAN.....	6
6. RECOMMENDATIONS .....	12
7. SCHEDULE OF FINDINGS.....	15
8. LEGAL CONSTRAINTS .....	26
9. LIMITATIONS OF THIS REPORT.....	27
10. TERMS AND DEFINITIONS.....	28
11. GLOSSARY OF TERMS.....	29
12. REFERENCES .....	30
13. APPENDICES .....	31
APPENDIX A - TABLE 1 TREE QUALITY ASSESSMENT .....	32
APPENDIX B - DEFAULT SPECIFICATION FOR PROTECTIVE BARRIER.....	34
APPENDIX C - TABLE B1- TREES AND THE PLANNING SYSTEM .....	36
APPENDIX D - PHOTOGRAPHS .....	37
APPENDIX E – BASE LINE DATA CAPTURE .....	47
APPENDIX F – SITE LOCATION PLAN .....	48
APPENDIX G – TREE CONSTRAINTS PLAN.....	49

## 1. INTRODUCTION

Steve Ambler & Sons Tree Specialists Ltd are instructed by Mr. Phil Booth (Senior Project Manager) Newport Norse) to undertake an arboricultural survey at Caerleon Comprehensive School, to assist in the submission of a planning application to the Local Planning Authority.

This survey is in accordance with the standards set out in BS 5837:2012<sup>1</sup> (items 4.4, 4.5 & 4.6) essentially to gather tree related information to assist the Local Planning Authority in their decision-making process, in the context of design, demolition and construction.

We have been provided with the following information -

→ ASP1797-Topographical Survey-Caerleon-2D (Newport Norse 2019)

We understand there is a proposal to redevelop the site, however, the trees have been assessed objectively and without reference to any site layout proposals.

It should be noted that some trees recorded in the tree schedule were not included in the original topographical survey and their positions as indicated on the Tree Constraints Plan is/are plotted approximately only.

The weather conditions were favourable for a survey of this nature and conducted from ground level on the 13<sup>th</sup> and 18<sup>th</sup> of June.2024.

The survey was undertaken by our Arboricultural surveyor who has 9 years' experience in the Arboricultural industry and holds the following qualifications:-

- a) Level 4 Diploma in Arboriculture
- b) Bachelor' s Degree in Geology
- c) Professional Tree Inspection Certificate (Lantra Awards)
- d) Technician Member of the Arboricultural Association
- e) Numerous City & Guilds Certificates in Tree Surgery related skills.

This Tree Survey Report is overseen by Steve Ambler who is the company founder and a professional arboriculturist with over 40 years' experience in the industry. His company was established in 1999 and later expanded during 2006 with the launch of a Specialist Tree Management section to become - Steve Ambler & Sons Tree Specialists Ltd. Steve holds the following arboricultural qualifications: -

- a) Fellow Member of the Arboricultural Association.
- b) Professional Diploma in Arboriculture (Royal Forestry Society)
- c) Professional Technician in Arboriculture (Arboricultural Association)
- d) Certificate in Arboriculture (Royal Forestry Society)
- e) LANTRA Award, "Bats and Arboriculture – A Guide for Practitioners" developed by The Bat Conservation Trust.

---

<sup>1</sup> British Standards Institute Publication "Trees in Relation to Design, Demolition and Construction - Recommendations' 2012

Unless otherwise stated, this Report remains valid for 12 months.

Where there is any recommendation within this Report for further investigation or diagnostic testing, climbing inspections, vegetation removal to allow a follow up survey etc., the onus is firmly on the Client to instruct such works in writing.

## 2. SITE DESCRIPTION AND OBSERVATIONS

The site is situated within and around the grounds of Caerleon Comprehensive school and is made up of numerous playing fields, car parks, paved pedestrian walkways and courtyards. The Northern area of the site is dominated by hard surfacing, and contains the school buildings, car parks and yards. The southeast and southwest areas are characterised by playing fields, with trees restricted to the periphery.

The northern and southeastern sections seem to receive high levels of usage, whereas the southwest section receives intermittent use.

At a low elevation, near the banks of the river Usk, the site is relatively sheltered from prevailing winds.

No soil analysis was carried out, however, data obtained from the Cranefield Soil and Agrifood Institute suggests that the area is dominated by freely draining slightly acid loamy soils.

The southeastern area of the site, beyond the school boundary, is within the Caerleon Conservation Area (1970) which the majority of site sits just outside of.

Nearest Post Code: NP18 1NF

What3words: ///fully.lively.state

### Category A Trees

No category A trees were recorded on site.

### Category B Trees

The following category B trees are recorded on the site, identified as – **G1, G2, G3, G7, G8, G9, G10, G12, G13, H1, H1b, T1, T3, T4, T5, T6, T7, T8, T16, T17, T20, T22, T23, T30, T32, T35, T38, T39, T40, and W1**

(These are trees which are large and prominent in the locality and in general good health and condition with some minor defects, or groups which cohesively provide screening of views into or out of the site (or between parts of it).

The remaining trees are not considered to be of any particular arboricultural or visual merit, are below the threshold of 75-mm diameter when measured at 1.5 metres above ground level or are in poor condition and have been allocated retention categories C or U.

A number of stumps were noted which are indicated on the attached plan with an 'X' .

**NOTE** - Category C trees are of little merit and need not necessarily be a significant constraint on the site' s potential as their loss may be mitigated through planting.

### 3. SPECIES RECORDED

Listed in alphabetical order -

- Aspen (*Populus tremula*)
- Austrian pine - *Pinus nigra austriaca*
- Bay tree - *Laurus nobilis*
- Bird cherry - *Prunus padus*
- Broad-leaved lime - *Tilia platyphyllos*
- Cockspur hawthorn - *Crataegus crus-galli*
- Common alder - *Alnus glutinosa*
- Common ash - *Fraxinus excelsior*
- Common hawthorn - *Crataegus monogyna*
- Common lime - *Tilia x vulgaris*
- Cotoneaster - *Cotoneaster sp.*
- Cultivar apple - *Malus domestica*
- Elder - *Sambucus nigra*
- European larch - *Larix decidua*
- European lime - *Tilia x europaea*
- Field maple - *Acer campestre*
- Grey alder - *Alnus incana*
- Hazel - *Corylus avellana*
- Horse chestnut - *Aesculus hippocastanum*
- London plane - *Platanus x hispanica*
- *Mixed species - Mixed species*
- Norway maple - *Acer platanoides*
- Pedunculate oak - *Quercus robur*
- Plum - *Prunus domestica*
- Red oak - *Quercus rubra*
- Rowan - *Sorbus aucuparia*
- Scots pine - *Pinus sylvestris*
- Silver birch - *Betula pendula*
- Silver maple - *Acer saccharinum*
- Snowy mespilus - *Amelanchier lamarckii*
- Swedish whitebeam - *Sorbus intermedia*
- Sweet gum - *Liquidambar styraciflua*
- Sycamore - *Acer pseudoplatanus*
- Weeping willow - *Salix babylonica*
- Whitebeam - *Sorbus aria*
- Wild cherry - *Prunus avium*
- Willow-leaved pear - *Pyrus salicifolia 'Pendula'*
- Wych elm - *Ulmus glabra*

#### 4. TREE SURVEY & TREE SURVEY PLAN

This tree survey will include each tree within the site boundary with a stem diameter of above 75-mm or in the case of large groups those measuring above 150-mm when measured at a height of 1.5-m above ground level. Trees over this size growing on land adjacent to the site, which are within a distance equal to 12 times their stem diameter from the boundary, are also included.

The surveyed tree/s are identified on the attached Tree Constraints Plan, within the Appendices, and the Schedule of Findings. This baseline data provides reference to an individual and the location of the tree using a tree reference number or tree tag number or both. Where tree tag number are used, a numbered tag is attached to the trunk of each tree at about 1.5-2.0 metres above ground level. A tabular format later in this Report records the baseline details of each tree or group against the reference number or numbered tag in the Findings tables Item 7.0.

The Report assigns the trees to one of four categories U, A, B, C (see Table One - Appendix A) depending on their overall health, size, condition, amenity, cultural and conservation value, their suitability in view of the increased usage that will arise following development. For trees in categories A to C, it should qualify under one or more of the three subcategories (1, 2, 3). Subcategories 1, 2, and 3 are intended to reflect arboricultural and landscape qualities, and cultural values, respectively. This system will also identify any unsuitable trees and suggest removal where necessary.

Where trees are found to require immediate attention, they will be identified in red bold text in the schedule of findings.

Care is needed when considering the quality and value of C grade and young trees, especially where they occur as individual specimens and should not dominate site layout considerations.

Trunk diameters are measured at 1.5 metres above ground level and rounded to the nearest 25 millimetres.

Trunk diameters and accessible crown spreads are measured with tree height, first significant branch and the lower crown ground clearance being estimated, unless otherwise stated.

**NOTE** - In all cases where a tree's position may be critical (e.g., in accurately determining clearances between a tree and a proposed structure) all dimensions should be checked on site.

#### 5. TREE CONSTRAINTS PLAN

A Tree Constraints Plan accompanies this Report and identifies a 'Root Protection Area' (RPA) for each tree or group of trees surveyed. The RPA is in effect a layout design tool indicating the minimum area around a tree or group deemed to contain sufficient roots and rooting volume to maintain tree viability and stability, and in which the protection of the roots and soil structure is treated as a priority. Where a tree is to be retained, its RPA should be respected from the initial design period and throughout the demolition works until completion of the build. The necessary RPA distances are found in Table D1 of the British Standards<sup>1</sup>.

The RPA is marked on the Tree Constraints Plan as a solid orange line and reflects a radial distance when measured from the centre of the tree's trunk which is shown as a circle, centred upon the trunk of the tree, to enclose an area equal to the required RPA. This measurement is replicated within the end column of the Schedule of Findings and again in tabular format and appears in the Tree Constraints Plan.

In practice, the distribution of roots may frequently prove to be uneven due to the presence of a variety of constraining influences. These may be physical barriers such as existing foundations etc., or the existence of localised soil conditions inhospitable to root growth, such as water logging or soil compaction. Conversely, soil conditions may be particularly conducive to root development in one quarter, and this might lead to an asymmetric distribution of roots around the tree. However, in most cases the nominal circular areas as indicated will provide a reasonable guide as to where special protection is needed.

Where pre-existing site conditions or other factors indicate that rooting has occurred asymmetrically, a polygon of equivalent area will be produced on the Tree Constraints Plan to represent this. Modifications to the shape of the RPA will reflect a soundly based arboricultural assessment of likely root distribution.

Proposed new planting may be marked on the plan as a constraint and the soil should be protected from compaction where this is to occur.

Trees will be coloured according to their category and the following will apply (Refer to 'Tree Quality Assessment 'and Tree Constraints Plan in the Appendices).

- U - Dark red
- A - Light green
- B - Mid blue
- C - Grey

**Planning Policy Wales 12** includes the following key paragraphs in relation to trees: -

#### Green Infrastructure Assessments

6.2.5 Green Infrastructure Assessments provide key evidence to support the preparation of development plans. Such Green Infrastructure Assessments should use existing datasets, and the best available information, to develop an integrated map-based evidence resource for biodiversity, ecosystem resilience.

6.2.6 Green Infrastructure Assessments should also draw from the evidence base provided by NRW' s Area Statements and Nature Network Maps, Wellbeing Assessments and locally and regionally collected green infrastructure data and mapping.

6.2.8 The need for ecosystems, habitats, and species to adapt to climate change and other pressures should be considered as part of the Green Infrastructure Assessment. This must include identifying ways to avoid or reverse the fragmentation of habitats, and to improve habitat connectivity where appropriate, through the promotion of wildlife corridors, protection of riverine corridors and identifying opportunities for land rehabilitation, reducing pollution, landscape management and habitat restoration, creation, and nature recovery.

6.2.9 Planning authorities must encourage the appropriate management of features of the landscape which are of major importance for wild flora and fauna in order to complement and improve the ecological coherence of the National Site Network, formally known as the Natura 2000 network.

6.2.11 The quality of the built environment should be enhanced by integrating green infrastructure into development through appropriate site selection and use of creative design.

6.2.14 Development proposals should be informed by the priorities identified in green infrastructure assessments and locally based planning guidance. The Building with Nature standards represents good practice and are an effective prompt for developers to improve the quality of their schemes and demonstrate the sustainable management of natural resources.

**The Step-Wise Approach**

The first priority for planning authorities is to avoid damage to biodiversity in its widest sense (i.e. the variety of species and habitats and their abundance) and ecosystem functioning.

6.4.16 The following factors will affect the implementation of the above stepwise approach: Preapplication surveys, research and data searches by developers will be necessary to establish the baseline state of biodiversity and ecosystem resilience on site taking into account the site’s contribution to resilient ecological networks through its diversity, extent, connectivity and condition and the provision of ecosystem services.

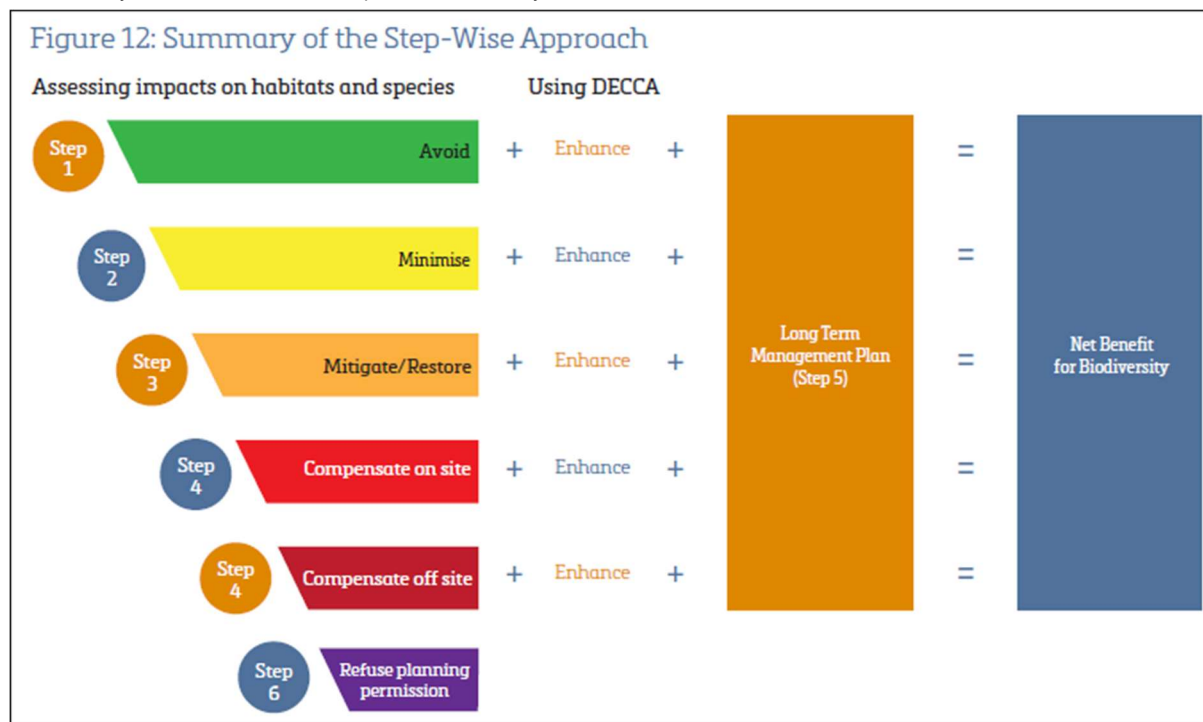

6.4.20 Statutorily designated sites must be protected from damage and deterioration, with their important features conserved and enhanced by appropriate management.

6.4.22 It should be recognised that all designated sites will have a unique and important role as part of ensuring resilient ecological networks and this contribution may be equally as important in a local context as its designation status. Distinctive & Natural Places Planning Policy Wales | Edition 12.

6.4.23 Planning authorities should consider opportunities to restore networks of habitats to a healthy condition identified as a result of undertaking the Green Infrastructure Assessment and the identification of appropriate interventions to secure delivery against the attributes of resilience, namely, diversity, extent, connectivity, condition and adaptability.

6.4.24 SSSIs are of national importance. The Wildlife and Countryside Act 1981, as amended by the Countryside and Rights of Way Act 2000, places a duty on all public bodies, including planning authorities, to take reasonable steps, consistent with the proper exercise of their functions, to further the conservation and enhancement of the features by reason of which a SSSI is of special interest.

6.4.25 Development in a SSSI which is not necessary for the management of the site must be avoided. This is a matter of principle to ensure that these sites can continue to fulfil their role at the heart of resilient ecological networks.

6.4.31 Sites of Importance for Nature Conservation, Local Wildlife Sites, Local Nature Reserves, and Regionally Importance Geodiversity Sites make a vital contribution to delivering an ecological network for biodiversity and resilient ecosystems, and they should be given protection in development plans and the development management process.

6.4.35 The presence of a species protected under European or UK legislation, or under Section 7 of the Environment (Wales) Act 2016 is a material consideration.

6.4.36 Developments are always subject to the legislation covering European protected species regardless of whether or not they are within a designated site.

### **Trees, Hedgerows and Woodlands**

6.4.37 Trees, hedgerows, groups of trees and areas of woodland are of great importance for biodiversity. They are important connecting habitats for resilient ecological networks and make an essential wider contribution to landscape character, culture, heritage and sense of place, air quality, recreation, and local climate moderation. They also play a vital role in tackling the climate emergency by locking up carbon, and can provide shade, shelter and foraging opportunities, wider landscape benefits such as air and diffuse pollution interception, natural flood management, and building materials. The importance of trees, in particular urban trees, in creating distinctive and natural places which deliver health and wellbeing benefits to communities, now and in the future should be promoted as part of plan making and decision taking.

6.4.38 Welsh native tree and hedge species, characteristic of the local area, provide a strong ecosystem resilience function, and they provide resources for local wildlife, particularly other native plants, and species. Native tree and hedge species can also complement opportunities for natural regeneration. Alongside broader woodland habitat types, such as wood pasture, parkland and traditional orchards, native tree and hedge species help to define our cultural heritage and landscape, creating a strong sense of place and connection to the past.

6.4.39 Planning authorities must protect trees, hedgerows, groups of trees and areas of woodland where they have ecological value, contribute to the character or amenity of a particular locality, or perform a beneficial green infrastructure function.

6.4.40 Where trees, woodland and hedgerows are present, their retention, protection and integration should be identified within planning applications. Where surveys identify trees, hedgerows, groups of trees and areas of woodland capable of making a significant contribution to the area, these trees should be retained and protected. The provision of services and

utilities infrastructure to the application site should also avoid the loss of trees, woodlands or hedges and must be considered as part of the development proposal; where such trees are lost, they will be subject to the replacement planting ratios set out below.

6.4.41 Whilst most focus within the planning system is targeted at urban trees, planning authorities should recognise the importance of trees within the countryside, either as woodlands, within hedgerows and hedge banks, or freestanding trees in fields, or as wood pasture.

6.4.42 Permanent removal of trees, woodland and hedgerows will only be permitted where it would achieve significant and clearly defined public benefits. Where individual or groups of trees and hedgerows are removed as part of a proposed scheme, planning authorities must first follow the stepwise approach.

Replacement planting shall be at a ratio equivalent to the quality, environmental and ecological importance of the tree(s) lost and this must be preferably onsite, or immediately adjacent to the site, and at a minimum ratio of at least 3 trees of a similar type and compensatory size planted for every 1 lost. Where a woodland or a shelterbelt area is lost as part of a proposed scheme, the compensation planting must be at a scale, design and species mix reflective of that area lost. In such circumstances, the planting rate must be at a minimum of 1600 trees per hectare for broadleaves, and 2500 trees per hectare for conifers.

6.4.15. Where loss is unavoidable developers will be required to provide compensatory planting (which is proportionate to the proposed loss as identified through an assessment of green infrastructure).

6.4.43 Ancient woodland, seminatural woodlands, individual ancient, veteran and heritage trees and ancient hedgerows are irreplaceable natural resources, and have significant landscape, biodiversity, and cultural value. Such trees, woodlands and hedgerows are to be afforded protection from development which would result in their loss or deterioration unless very exceptionally there are significant and clearly defined public benefits; this protection must prevent potentially damaging operations and their unnecessary loss.

6.4.44 The protection and planting of trees and hedgerows should be delivered, where appropriate, through locally specific strategies and policies, through imposing conditions when granting planning permission, and/or by making Tree Preservation Orders (TPOs).

In addition, following legislation applies -

#### **The Town & Country Planning Act 1990.**

Section 197 of the Act places an express duty on the local planning authority, when granting planning permission, to ensure whenever appropriate that adequate conditions are imposed to secure the preservation or planting of trees, and that any necessary tree preservation orders are made under section 198 of the Act. When granting outline planning permission, the authority may consider it appropriate to impose a condition requiring the submission of particular details relating to trees to be retained on the site, such as their location in relation to the proposed development and their general state of health and stability. When granting detailed planning permission, conditions may be used to secure the protection of trees to be retained, for example by requiring the erection of fencing around trees during development or restricting works which are likely to adversely affect them. The long-term protection of trees, however, should be secured by Tree Preservation Orders (TPO) rather than by condition: such orders may also be expedient for the temporary protection of

existing trees until details of the reserved matters are submitted and it becomes clear whether there is a need to retain the trees.

**Well-being of Future Generations (Wales) Act 2015.**

Long term: A greener city is a healthier city environmentally and encourages investment and employment opportunities. Natural green space supports social resilience and community wellbeing, making the environment healthier for both people and wildlife.

Planning decisions aim to build sustainable and cohesive communities in both the built and green environment.

Prevention: Sound decisions help promote a greener environment, via TPOs for trees and woodlands and hedgerows, and reduces the loss of trees and woodlands and hedgerows on private land. Trees and woodlands and hedgerows are essential in the fight against climate change, as they sequester carbon, and assist with increased biodiversity.

The provision and acceptance of this report are subject to the general terms and conditions of Steve Ambler & Sons Tree Specialists Ltd, which can be made available upon request.

## 6. RECOMMENDATIONS

Your attention is drawn to the condition of tree and group numbers G11, T15 & T18. These trees are considered to be in a dangerous condition, and the remedial actions within the management recommendations of the Schedule of Findings must be immediately implemented.

Recommended date of a tree condition inspection<sup>2</sup>: 13/12/2025

Efforts should be made to retain category A and B trees.

C category trees may be retained if desired although not need necessarily be a significant constraint on the site' s potential.

Category U trees should be removed as part of any site development and evaluated through a site risk assessment in the sites existing current situation.

Design and layout should take account of existing trees of importance and consider their requirements to maintain existing landscape value where possible. The site layout should ensure construction activity is outside the Root Protection Area of any retained trees. Recommended minimum Root Protection Area radii are shown in the final column of the survey schedule and diagrammatically as circles on the Tree Constraints Plan.

ANY LANDOWNER OR LAND MANAGER SHOULD BE AWARE THAT - Trees must receive regular tree inspections by persons with adequate specialist arboricultural qualifications. A landowner has a duty of care imposed by statute and common law to do so and keep records of such (see legal constraints below). For further advice contact [www.trees.org.uk](http://www.trees.org.uk)

Tree felling and surgery works should only be undertaken by trained, competent and appropriately certificated personal with adequate experience and public, third party and employers liability insurance to 5,000,000 pounds. Always ask for proof from the contractors prior to engagement and seek references where necessary.

In view of the recommendations for the design and construction process, in considering tree care (Figure 1, Appendix A), further assessments are required throughout the planning and design phase and recommended as follows...

- (1) **Arboricultural Implications Assessment (AIA)**
- (2) **Tree Protection Plan (TPP),**
- (3) **Arboricultural Method Statement (AMS)** which should be undertaken by an 'Arboriculturalist' .

Tree clearance works or works other than those to deal with serious defects posing considerable risk shall not commence until such time written approval or full planning approval is received from the Local Planning Authority. Any authorised

---

<sup>2</sup> Any instructions from our client to undertake the physical tree works recommended in Section 7 of this Report will not invoke the future recommendations for undertaking inspections or monitoring. This must be formerly instructed in writing, citing the date and full title of the Report, the exact recommended items instructed and providing the relevant tree references. No liability will be accepted where liabilities arise due to any absence in future monitoring, which is not instructed separately.

tree works should be completed prior to the onset of any demolition or construction works, taking account of all legal constraints.

All the retained trees should be re-examined by an arboricultural specialist, once the development is complete.

Where the installation of paths or lightweight structures such as walls are unavoidable near to trees, the design and construction specification needs to take account of future growth. Refer to Table A of the Standard.

Shading of buildings by trees can be a problem, particularly where there are rooms which require natural light. Buildings will need to be positioned further away than just the outer edge of tree canopies to reduce the likelihood of pressure from future occupiers for tree removal or trimming. This applies particularly where windows of habitable rooms will face onto tree canopies. Future dimensions of immature trees and shadow patterns should also be considered. A minimum of 2-m should be allowed between buildings and the outer edge of fully-grown canopies to allow for building maintenance and the erection of scaffolding etc.

Proposed buildings should be designed to take account of existing trees that are to be retained, their ultimate size and density of foliage, and the effect that these will have on the availability of light. Where sufficient distances (including allowances for future growth) cannot be achieved, the removal of C category trees should be considered. Larger trees are unlikely to increase greatly in height or spread. Older trees are particularly sensitive to root disturbance and are best retained within open space where they can be managed for optimum health, amenity value, and safety, rather than within private spaces.

All trees being retained must be protected by barriers and/or ground protection before -

- Any site activity, except for tree clearance.
- Materials or machinery are brought onto site.
- Demolition of any kind.
- Removal of surfaces.
- Stripping of soil.
- Stripping of vegetation.

Where all activity can be excluded from the RPA, vertical barriers should be erected to create a construction exclusion zone. Where construction activity cannot be fully or permanently excluded in this manner from all or part of a tree's RPA, appropriate ground protection should be installed (see 6.2.2 and Figure 2 of the standard) working under the guidance of an approved AMS and the supervision of the Project Arborist.

The default specification should consist of a vertical and horizontal scaffold framework, well braced to resist impacts, as illustrated in Figure 2 in the Appendices. The vertical tubes should be spaced at a maximum interval of 3 metres and driven securely into the ground. Onto this framework, welded mesh panels should be securely fixed. Care should be exercised when locating the vertical poles to avoid underground services and, in the case of the bracing poles, to avoid contact with structural roots. If the presence of underground services precludes the use of driven poles, an alternative specification should be prepared in conjunction with the project arboriculturist that provides an equal level of protection. Such alternatives could include the attachment of the panels to a free-standing scaffold support framework.

**In order to prevent damage to the trees, including their roots, within the fenced area (RPA) there should be no...**

- Alteration of ground levels, including soil stripping and digging.
- Installation of drainage or services using conventional open trenching methods which would not be in accordance with BS: 5837. (Any works should be in accordance with the National Joint Utilities NJUG Guidelines for the Planning, Installation and Maintenance of Utility Apparatus in Proximity to Trees Volume 4)
- Excavation (there are exceptions when covered by an approved<sup>3</sup> Arboricultural Method Statement)
- Storage of any materials or equipment, even on a temporary basis.
- Storage of oil, bitumen, cement or other harmful materials, mixed or discharged within 12-m of the trunk of any retained tree and making further allowances for any slope of the ground to prevent running contamination. Phytotoxic materials would include any mineral oil, fuels, cement mortar washings concrete washings, mortar.
- Fires must not be lit beneath or within 12-m of any tree canopies.
- Site operations such as - deliveries, site machines, crane jibs etc (should be organised to avoid damaging the trunk or crown of trees). Where this conflict is unavoidable, then facilitation pruning should be carried out in advance, rather than after damage has occurred. This may also be required to allow demolition operations. (Facilitation pruning will require the consent of the LPA and should be under the guidance of the PA.
- Mechanical cultivation of the soil as part of landscaping operations.

Tree felling and surgery may be required to allow access for construction or future site traffic, or in the interests of the future health and safety. Detailed recommendations for such works can be provided once a final site layout is agreed and it is determined which trees (if any) are to be retained. All surgery should comply with the British Standards 3998:2010 Tree Work Recommendations or more recently accepted arboricultural good practice. The legal position regarding site designations should be considered.

---

<sup>3</sup> Approved by the Local Planning Authority

**7. SCHEDULE OF FINDINGS**

Tree Number	Tree Tag	Species	Height (M)	Effectual Diameter (mm)	Branch Spread (M)				1st Significant Branch (M)	Canopy Clearance (M)	Life stage	General Observations	Preliminary Management Recommendations	Remaining Contribution (years)	Retention Category	Root Protection Area (M2)	Root Protection Radius (M radius)	Photo Ref
					N	E	S	W										
G1	N/A	Common lime London plane	22	500	8	8	8	8	10	10	EM	A row of trees, separated from site by security fencing but within influencing distance and significantly overhanging the boundary fence. Small to medium diameter deadwood overhanging the site boundary. Provides reasonably good screening between site and the neighbouring sports ground. Hard surfacing likely limits root incursion into site (reflected on the TCP) Dense ivy and occluding vegetation restrict inspection around base.	Remove deadwood greater than 50mm in diameter overhanging site. Sever and remove 1m ivy bands around the bases of trees to allow for a detailed inspection. Qualified arboriculturalist to be advised once visibility works are completed.	20-40	B2	113	6.0	1
G2	N/A	Sycamore Rowan Silver maple Swedish whitebeam	18	500	5	5	5	5	4	4	EM	A row of trees separated from site by security fencing but within influencing distance and significantly overhanging the boundary fence. Providing reasonably good screening between site and the neighbouring sports ground. Hard surfacing likely limits root incursion into site. Dense ivy, epicormic growth and occluding vegetation restrict inspection of the base.	Remove dense ivy, epicormic growth and occluding vegetation around the bases of trees to allow for a detailed inspection. Qualified arboriculturalist to be advised once visibility works are completed.	20-40	B2	113	6.0	/
G3	N/A	Sycamore London plane Common ash Broad-leaved lime	15	450	6	6	6	6	3	3	EM	A row of trees belonging to the neighbouring sports pitches, providing good screening to their southern boundary. Western end of the group comes within influencing distance of the site, overhanging the boundary fence by 0.5m.	No action required at this time.	20-40	B2	91	5.4	/

Tree Number	Tree Tag	Species	Height (M)	Effectual Diameter (mm)	Branch Spread (M)				1st Significant Branch (M)	Canopy Clearance (M)	Life stage	General Observations	Preliminary Management Recommendations	Remaining Contribution (years)	Retention Category	Root Protection Area (M <sup>2</sup> )	Root Protection Radius (M radius)	Photo Ref
					N	E	S	W										
		Norway maple Field maple																
G4	N/A	Swedish whitebeam Sycamore Field maple	10	100	1	1	1	1	2	2	EM	Unremarkable trees of average form. Separated from site by security fencing but crowns overhanging by 0.5m	No action required at this time.	20-40	C2	4	1.2	/
G5	N/A	European larch Scots pine	13	320	3	3	3	3	2.5	1.5	EM	Trees of average form, beyond the security fence but overhanging site. Low crown density observed in the larch tree.	Reinspect Larch annually during summertime to monitor crown health.	20-40	C2	46	3.8	/
G6	N/A	Hazel	8	120	4	4	4	4	2	2	EM	Hazel coppice regrowth, outside of site but within influencing distance and overhanging the boundary fence in some areas. Provides good screening at the site boundary.	No action required at this time.	20-40	C2	6	1.4	/
G7	N/A	Common alder Common ash Silver birch	16	350	3	3	3	3	4	2	EM	Trees of reasonable form. Outside of site but within influencing distance. Ash Dieback Disease ( <i>Hymenoscyphus fraxineus</i> ) health stage 2 observed throughout the Ash component of the group. Goat willow with 75% crown dieback (location indicated on the tree constraints plan)	Fell goat willow with 75% crown dieback indicated on the tree constraints plan. Reinspect annually during the summertime to monitor the Ash component of the group for progression of Ash Dieback Disease.	20-40	B2	55	4.2	2
G8	N/A	European lime	18	500	6	6	6	6	3	3	M	Trees outside of site but within influencing distance. Observed from a distance with all dimensions estimated.	No action required at this time.	20-40	B2	113	6.0	/

Tree Number	Tree Tag	Species	Height (M)	Effectual Diameter (mm)	Branch Spread (M)				1st Significant Branch (M)	Canopy Clearance (M)	Life stage	General Observations	Preliminary Management Recommendations	Remaining Contribution (years)	Retention Category	Root Protection Area (M2)	Root Protection Radius (M radius)	Photo Ref
					N	E	S	W										
G9	N/A	Broad-leaved lime	20	450	6	6	6	6	8	8	M	Linear group within the neighbouring cemetery. Providing some screening between site and the cemetery, though this is limited due to the high crown clearance of these trees. Separated from site by security fencing. Hard surfacing coverage to 500mm from the site boundary, limiting root growth into site.	No action required at this time.	20-40	B2	91	5.4	/
G10	N/A	Swedish whitebeam Pedunculate oak Norway maple Common ash Horse chestnut Sycamore	18	450	4	4	4	4	2	2	EM	Trees of reasonably good form lining the rugby pitch. Ash Dieback Disease ( <i>Hymenoscyphus fraxineus</i> ) health stage 2 observed in the ash component of the group.  Medium and large diameter deadwood observed over the footpath.	Reinspect the Ash component of the group annually during the summertime to monitor for the development of Ash Dieback Disease.  Remove deadwood greater than 50 mm in diameter from above the footpath.	20-40	B2	91	5.4	/
G11	N/A	Common ash	17	500	4	4	4	4	4	2	EM	Ash Dieback Disease ( <i>Hymenoscyphus fraxineus</i> ) health stage 3 observed.	Fell to ground level.	<10	U	0	0.0	/
G12	N/A	Sycamore Common ash	18	450	11	11	11	11	4	2	EM	Trees of reasonably good form lining the rugby pitch. Ash Dieback Disease ( <i>Hymenoscyphus fraxineus</i> ) health stage 2 observed in the ash component of the group.	Reinspect the Ash component of the group annually during the summertime to monitor for the development of Ash Dieback Disease.	20-40	B2	91	5.4	/
G13	N/A	Swedish whitebeam	16	450	4	4	4	4	3	2	EM	Trees of reasonably good form. Providing screening between the rugby field and neighbouring car park.	No action required at this time.	20-40	B2	91	5.4	/

Tree Survey, Categorisation & Constraints Report at Caerleon Comprehensive School Dated: June 2024

Tree Number	Tree Tag	Species	Height (M)	Effectual Diameter (mm)	Branch Spread (M)				1st Significant Branch (M)	Canopy Clearance (M)	Life stage	General Observations	Preliminary Management Recommendations	Remaining Contribution (years)	Retention Category	Root Protection Area (M <sup>2</sup> )	Root Protection Radius (M radius)	Photo Ref
					N	E	S	W										
H1a,b	N/A	Field maple Elder Common hawthorn	7	120	2	2	2	2	0.5	0	EM	Hedgerow outside of site but within influencing distance. Provides good screening at the site boundary. Two dead elm trees within falling distance of the site boundary, indicated on the tree constraints plan.	Remove dead elm trees as indicated on the Tree Constraints Plan.	20-40	B2	6	1.4	3
T1	N/A	Whitebeam	14	400	4	4	4	4	6	6	EM	A tree of below average form, suppressed by neighbouring trees, multi-stemmed and with ivy extending into the lower crown, limiting visibility of the base and stem.  Provides reasonably good screening as part of a group with G1.	Sever and 1m ivy band around the base to allow detailed inspection of the main stem. Qualified arboriculturist to be notified once visibility works are complete.	20-40	B2	72	4.8	/
T2	N/A	Sycamore	20	500	7	7	7	7	8	8	EM	A tree of poor form. 50-75% crown dieback isolated to the southern side of the crown. Possibly due to pesticide or other Chemical use on the rugby pitch to the south. Ivy clad stem limits inspection.	Sever and remove ivy and occluding vegetation to a height of 2m above ground level to allow detailed inspection of the main stem. Qualified arboriculturist to be notified once visibility works are complete.	10-20	C2	113	6.0	4, 5
T3	N/A	Whitebeam	14	400	4	4	4	4	6	6	EM	A tree of below average form, suppressed by neighbouring trees, multi-stemmed and with ivy extending into the lower crown, limiting visibility of the base and stem.  Provides reasonably good screening as part of a group with G1.	Sever and remove 1m ivy band around the bases of the tree to allow for a detailed inspection. Qualified arboriculturist to be advised once visibility works are completed.	20-40	B2	72	4.8	/

Tree Number	Tree Tag	Species	Height (M)	Effectual Diameter (mm)	Branch Spread (M)				1st Significant Branch (M)	Canopy Clearance (M)	Life stage	General Observations	Preliminary Management Recommendations	Remaining Contribution (years)	Retention Category	Root Protection Area (M2)	Root Protection Radius (M radius)	Photo Ref
					N	E	S	W										
T4	N/A	Sycamore	18	450	5.5	5.5	5.5	5.5	4	4	EM	A tree of reasonably good form. Beyond the security fencing but within influencing distance of site. Crown slightly overhangs the boundary fence.	Sever and remove 1m ivy band around the base to allow for a detailed inspection. Qualified arboriculturalist to be advised once visibility works are completed.	20-40	B2	91	5.4	/
T5	1782	Silver birch	15	280	4	5	2	3	2.5	1.5	EM	Tree of reasonable form in a grass area at the centre of a turning circle. The quality of the already limited rooting area has been impeded by soil compaction related to car parking on the grass between and alongside trees in this area.	Consider taking steps to prevent parking on the grass around the trees and decompaction measures.	20-40	B2	35	3.4	/
T6	1783	Silver birch	15	400	3	4	5	2.5	3	2	EM	Tree of reasonable form in a grass area at the centre of a turning circle. The quality of the already limited rooting area has been impeded by soil compaction related to car parking on the grass between and alongside trees in this area.	Consider taking steps to prevent parking on the grass around the trees and decompaction measures.	20-40	B2	72	4.8	6
T7	1784	Silver birch	15	360	3.5	2.5	3.5	4	2.5	1.5	EM	Tree of reasonable form in a grass area at the centre of a turning circle. The quality of the already limited rooting area has been impeded by soil compaction related to car parking on the grass between and alongside trees in this area.	Consider taking steps to prevent parking on the grass around the trees and decompaction measures.	20-40	B2	58	4.3	/
T8	1785	Silver birch	15	270	5	2	2.5	2.5	3.5	1.5	EM	Tree of reasonable form in a grass area at the centre of a turning circle. The quality of the already limited rooting area has been impeded by soil compaction related to car parking on the grass between and alongside trees in this area.	Consider taking steps to prevent parking on the grass around the trees and decompaction measures.	20-40	B2	32	3.2	/

Tree Number	Tree Tag	Species	Height (M)	Effectual Diameter (mm)	Branch Spread (M)				1st Significant Branch (M)	Canopy Clearance (M)	Life stage	General Observations	Preliminary Management Recommendations	Remaining Contribution (years)	Retention Category	Root Protection Area (M2)	Root Protection Radius (M radius)	Photo Ref
					N	E	S	W										
T9	N/A	Bay tree	7	80	0.5	0.5	0.5	0.5	0	0	EM	An unremarkable tree of average form. Separated from site by security fencing.	No action required at this time.	20-40	C2	2	1.0	/
T10	N/A	Grey alder	10	170	1	1	1	1	3	2	EM	An unremarkable tree of average form. Separated from site by security fencing, though the crown overhangs into site by 1m.	No action required at this time.	20-40	C2	13	2.0	/
T11	N/A	Bay tree	7	80	0.5	0.5	0.5	0.5	0	0	EM	An unremarkable tree of average form. Separated from site by security fencing.	No action required at this time.	20-40	C2	2	1.0	/
T12	N/A	Grey alder	10	170	1	1	1	1	3	2	EM	An unremarkable tree of average form. Separated from site by security fencing, though the crown overhangs into site by 1m.	No action required at this time.	20-40	C2	13	2.0	/
T13	N/A	Grey alder	10	170	2	2	2	2	3	1.5	EM	An unremarkable tree of average form. Separated from site by security fencing, though the crown overhangs into site by 1m.	No action required at this time.	20-40	C2	13	2.0	/
T14	N/A	Rowan	7	80	1	1	1	1	2	2	Y	An unremarkable tree of average form. Outside of site but overhanging the security fence at the boundary.	No action required at this time.	20-40	C2	2	1.0	/
T15	N/A	Wych elm	8	120	3	3	3	3	1.5	1.5	EM	Standing dead with full crown intact.	Fell to ground level.	<10	U	0	0.0	/
T16	1786	Austrian pine	10	240	2.5	2.5	2	2.5	3	2	EM	A tree of reasonable form near the site boundary.	No action required at this time.	20-40	B2	26	2.9	/
T17	1787	Austrian pine	10	220	1.5	1.5	1.5	1.5	2	1.5	EM	A tree of reasonable form near the site boundary.	No action required at this time.	20-40	B2	21	2.6	/

Tree Number	Tree Tag	Species	Height (M)	Effectual Diameter (mm)	Branch Spread (M)				1st Significant Branch (M)	Canopy Clearance (M)	Life stage	General Observations	Preliminary Management Recommendations	Remaining Contribution (years)	Retention Category	Root Protection Area (M2)	Root Protection Radius (M radius)	Photo Ref
					N	E	S	W										
T18	N/A	Elder	2.5	80	1	1	1	1	0	0	EM	Standing dead with full crown intact. Very low target occupancy.	Fell to ground level.	<10	U	0	0.0	/
T19	1788	Bird cherry	7	170	2	1.5	2.5	2	2	1	EM	An unremarkable tree of below average form. 10% crown dieback noted.	Reinspect annually in the summertime to monitor crown health.	10-20	C2	13	2.0	/
T20	2808	Wild cherry	15	350	4	4.5	5	3	3	1	EM	A tree of reasonable form at the edge of W1 but separate from the rest of the group by security fencing. Small to medium diameter deadwood throughout the crown.	No action required at this time.	20-40	B2	55	4.2	/
T21	N/A	Rowan	8	150	2	2	2	2	2	1	EM	An unremarkable tree of average form within a clearing of W1.	No action required at this time.	20-40	C2	10	1.8	/
T22	1789	Common alder	15	340	3.5	3.5	3.5	3.5	2.5	0	EM	A tree of reasonable form in a grass verge in the staff car park.	No action required at this time.	20-40	B2	52	4.1	/
T23	1790	Norway maple	9	190	2.5	2.5	2.5	2.5	3	1.5	EM	A tree of reasonable form in a grass verge in the staff car park.	No action required at this time.	20-40	B2	16	2.3	/
T24	2791	Broad-leaved lime	15	410	2.5	2.5	2.5	2.5	2	0.5	EM	Tree in a small grassy area between the car park and school buildings. Retaining wall restricts root growth to the east. Block paving to the west has some evidence of root incursion beneath with slightly raised kerb stones, likely lifted through secondary thickening of roots. Part of a row of trees have been populated within the last 3-4 years, there is scope to adjust the RPA's to reflect this if they pose a major constraint to site.	Consider expanding the paving free area around the base of the tree to improve rooting conditions. Re-pollard to previous Pollard points and continue to cyclically re-pollard every 2-3 years.	20-40	C2	76	4.9	7

Tree Number	Tree Tag	Species	Height (M)	Effectual Diameter (mm)	Branch Spread (M)				1st Significant Branch (M)	Canopy Clearance (M)	Life stage	General Observations	Preliminary Management Recommendations	Remaining Contribution (years)	Retention Category	Root Protection Area (M2)	Root Protection Radius (M radius)	Photo Ref
					N	E	S	W										
T25	1779	Broad-leaved lime	15	410	2.5	2.5	2.5	2.5	2	0.5	EM	Tree in a small grassy area between the car park and school buildings. Retaining wall restricts root growth to the east. Block paving to the west has some evidence of root incursion beneath with slightly raised paving slabs, likely lifted through secondary thickening of roots. Part of a row of trees have been pollarded within the last 3-4 years, there is scope to adjust the RPA's to reflect this if they pose a major constraint to site.	Consider expanding the paving free area around the base of the tree to improve rooting conditions. Re-pollard to previous pollard points and continue to cyclically re-pollard every 2-3 years.	20-40	C2	76	4.9	/
T26	2792	Broad-leaved lime	15	610	2.5	2.5	2.5	2.5	2	0.5	EM	Tree in a small grassy area between the car park and school buildings. Retaining wall restricts root growth to the east. Block paving to the west has some evidence of root incursion beneath with slightly raised paving slabs, likely lifted through secondary thickening of roots. Part of a row of trees have been pollarded within the last 3-4 years, there is scope to adjust the RPA's to reflect this if they pose a major constraint to site.	Consider expanding the paving free area around the base of the tree to improve rooting conditions. Re-pollard to previous pollard points and continue to cyclically re-pollard every 2-3 years.	20-40	C2	168	7.3	8
T27	2793	Broad-leaved lime	15	410	2.5	2.5	2.5	2.5	2	0.5	EM	Tree in a small grassy area between the car park and school buildings. Retaining wall restricts root growth to the east. Block paving to the west has some evidence of root incursion beneath with slightly raised paving slabs, likely lifted through secondary thickening of roots. Part of a row of trees have been pollarded within the last 3-4 years, there is scope to adjust the RPA's to reflect this if they pose a major constraint to site.	Consider expanding the paving free area around the base of the tree to improve rooting conditions. Re-pollard to previous pollard points and continue to cyclically re-pollard every 2-3 years.	20-40	C2	76	4.9	/

Tree Number	Tree Tag	Species	Height (M)	Effectual Diameter (mm)	Branch Spread (M)				1st Significant Branch (M)	Canopy Clearance (M)	Life stage	General Observations	Preliminary Management Recommendations	Remaining Contribution (years)	Retention Category	Root Protection Area (M2)	Root Protection Radius (M radius)	Photo Ref
					N	E	S	W										
T28	2794	Broad-leaved lime	15	470	2.5	2.5	2.5	2.5	2	0.5	EM	Tree in a small grassy area between the car park and school buildings. Retaining wall restricts root growth to the east. Block paving to the west has some evidence of root incursion beneath with slightly raised paving slabs, likely lifted through secondary thickening of roots. Part of a row of trees have been pollarded within the last 3-4 years, there is scope to adjust the RPA's to reflect this if they pose a major constraint to site.	Consider expanding the paving free area around the base of the tree to improve rooting conditions. Re-pollard to previous pollard points and continue to cyclically re-pollard every 2-3 years.	20-40	C2	99	5.6	9
T29	2795	Broad-leaved lime	15	480	2.5	2.5	2.5	2.5	2	0.5	EM	Tree in a 3x3m planting out surrounded by hard surfacing. The planting pit provides a rooting area of 9m <sup>2</sup> , inadequate to maintain a tree of this size, though no evidence of decline is visible in the crown. It is likely that the root system has developed beneath the surrounding block paving. Displaced slabs near the tree provide evidence for this.	Consider expanding the planting pit around the base of the tree to improve rooting conditions.	20-40	C2	104	5.8	/
T30	1796	Wild cherry	12	320	5	4.5	4	4.5	2.5	1.5	EM	A tree of reasonable form within a garden area.	No action required at this time.	20-40	B2	46	3.8	/
T31	N/A	Cotoneaster	4	90	1	1	1	1	1.5	1	Y	Unremarkable tree of average form.	No action required at this time.	20-40	C2	3	1.1	/
T32	2802	Weeping willow	20	880	6.5	8	4	6.5	5	1	M	A tree of seemingly reasonable form. Dense ivy growth restricts detailed inspection of the main stem which appears to have an old tear out wound at 2m above ground level.	Sever and remove ivy to allow for a detailed inspection of the main stem.	20-40	B2	350	10.6	10
T33	140	Plum	4	130	1	1	1	1	2	2	Y	An unremarkable tree of average form.	No action required at this time.	40+	C2	7	1.6	/

Tree Survey, Categorisation & Constraints Report at Caerleon Comprehensive School Dated: June 2024

Tree Number	Tree Tag	Species	Height (M)	Effectual Diameter (mm)	Branch Spread (M)				1st Significant Branch (M)	Canopy Clearance (M)	Life stage	General Observations	Preliminary Management Recommendations	Remaining Contribution (years)	Retention Category	Root Protection Area (M2)	Root Protection Radius (M radius)	Photo Ref
					N	E	S	W										
T34	N/A	Cultivar apple	3	100	2	2	2	2	1.5	1.5	Y	An unremarkable tree of average form in a fenced off area. Observed from a distance with all dimensions estimated.	No action required at this time.	40+	C2	4	1.2	/
T35	N/A	Cultivar apple	3	160	2	4	6	4	1	1	EM	A tree of reasonable form in a fenced off area. Observed from a distance with all dimensions estimated.	No action required at this time.	40+	B2	11	1.9	/
T36	N/A	Cultivar apple	5	130	2.5	2.5	2.5	2.5	1.5	1.5	Y	An unremarkable tree of average form in a fenced off area. Observed from a distance with all dimensions estimated.	No action required at this time.	40+	C2	7	1.6	/
T37	N/A	Cockspur hawthorn	5	100	2	2	2	2	1.5	1.5	Y	An unremarkable tree of average form.	No action required at this time.	40+	C2	4	1.2	/
T38	1798	Willow-leaved pear	10	370	5	5	5	5	1.5	1.5	EM	A tree of reasonable form in a garden area.	No action required at this time.	20-40	B2	61	4.4	/
T39	1799	Snowy mespilus	7	120	2	2	2	2	2	2	EM	An unremarkable tree of average form.	No action required at this time.	20-40	B2	6	1.4	/
T40	N/A	Sycamore	14	350	4	4	4	4	2.5	2.5	EM	A tree of reasonably good form at the edge of the rugby field. Makes up part of a row but will be somewhat isolated following the removal of the neighbouring Ash trees.	No action required at this time.	20-40	B2	55	4.2	/
T41	N/A	Wild cherry	7	20	2	2	2	2	2	2	Y	An unremarkable tree of average form providing minimal screening between the rugby pitch and car park.	No action required at this time.	20-40	C2	0	0.2	/
T42	N/A	Sweet gum	8	200	4	4	4	4	2	2	EM	Tree of reasonable form, provides reasonable screening between the rugby fields and the neighbouring car park.	No action required at this time.	20-40	C2	18	2.4	/

Tree Number	Tree Tag	Species	Height (M)	Effectual Diameter (mm)	Branch Spread (M)				1st Significant Branch (M)	Canopy Clearance (M)	Life stage	General Observations	Preliminary Management Recommendations	Remaining Contribution (years)	Retention Category	Root Protection Area (M2)	Root Protection Radius (M radius)	Photo Ref
					N	E	S	W										
T43	N/A	Wild cherry	8	250	3	3	3	3	2.5	2.5	EM	Tree of reasonable form provides reasonable screening between the rugby fields and the neighbouring car park. Low crown density and leaf discolouration observed.	Reinspect annually in the summertime to monitor crown health.	10-20	C2	28	3.0	/
T44	N/A	Wild cherry	8	250	3	3	3	3	2.5	2.5	EM	Tree of reasonable form provides reasonable screening between the rugby fields and the neighbouring car park. Low crown density and leaf discolouration observed.	Reinspect annually in the summertime to monitor crown health.	10-20	C2	28	3.0	/
W1	N,/A	Wild cherry Aspen Pedunculate oak Red oak Common ash Horse chestnut Rowan Sycamore	17	500	7	7	7	7	2	1.5	M	Woodland school area, separated from the rest of site by security fencing. Ash Dieback Disease ( <i>Hymenoscyphus fraxineus</i> ) health stage 1-2 observed throughout the Ash component of the group.	Reinspect annually during the summertime to monitor for Ash dieback Disease.	40+	B2,3	113	6.0	/

NOTES.

- Tree felling should only be undertaken by trained, competent and appropriately certificated personal with adequate experience and public liability insurance to £5,000,000. Always ask for proof from the contractors prior to engagement and seek references where necessary. Trees must receive regular tree inspections by persons with adequate specialist qualifications. For further advice contact [www.trees.org.uk](http://www.trees.org.uk)

## 8. LEGAL CONSTRAINTS

### Tree Preservation Orders and Conservation Area Status in Wales

In Wales, the law on TPOs is in Part V111 of the Town and Country Planning Act 1990 Town and Country Planning (Trees) Regulations 1999. When any tree/s are protected by a TPO or are situated within a Conservation Area, it is an offence (1) cut down (2) uproot (3) top (4) lop (5) wilfully damage or (6) wilfully destruct a tree without the express written permission from the Local Planning Authority (LPA), there are exceptions. A LPA may grant permission, if considered reasonable following the submission of an application for consent to undertake the works, or where in accordance with an Approved Planning Application or under the exemptions within the Town and Country Planning Act 1990 of dead, dying, or dangerous. It is advisable to consult the LPA and an Arborist prior to conducting any tree works under these exemptions.

### Felling License

A Felling Licence may be required in certain felling operations, and these are administered by the Forestry Commission where more than five cubic metres of wood are felled in one calendar quarter and when selling more than two cubic metres. There are exceptions, and these are in the Forestry Act 1967 and Regulations made under this Act. Contravention of the felling licence controls can incur substantial penalties. Tree felling forming part of a Local Authority Planning Approval is exempt.

Tree work operations have the potential to impact on protected species, most notably birds and bats. **The Wildlife and Countryside Act 1981** is the primary legislation which protect birds in the UK, and it is an offence, with certain exceptions, to intentionally kill, injure or take any wild bird, or intentionally take, damage or destroy the nest of any wild bird while it is in use or being built or take or destroy an egg of any wild bird. Certain species of bird are afforded additional protection, whereby it is an offence to intentionally or recklessly disturb any wild bird included on Schedule 1 of the Act, while it is nest building or at a nest containing eggs or young or disturb the dependent young of such a bird.

It is not an offence to fell trees during the bird nesting period (which is generally considered to be between mid-February and September inclusive) providing it is done so without breaching the legislation detailed above.

Caution must be aired if tree works are programmed during the nesting season as there is potential for delay if nesting birds are found on site. Should nesting birds be present, then all but essential works must be postponed. If in undertaking essential works a nest or nests are found to be present, then further advice must be sought from the statutory nature conservation authority, which in Wales is Natural Resources Wales and in England is Natural England, or from an appropriately qualified ecologist. The penalty for disturbing or destroying one bird or nest can be an unlimited fine and up to six months in prison, or both.

### Bats...Summary of Current Relevant Legislation

Bats are also generally associated with trees and can be impacted by tree work operations. There are some 17 species of bat which are known to breed in the British Isles, all are insectivorous and depend to some extent on habitat in which trees are a significant element. Bats are a protected species and are in decline both globally and nationally. Therefore, they are to be fully considered before any tree work commences and particularly if the trees are mature. All species of bats are afforded **full** protection under the **Conservation of Habitats and Species Regulations 2017 (as amended)** and **partial** protection under the **Wildlife and Countryside Act 1981 (as amended)**. It is an offence (with limited exceptions) to deliberately take, injure, or kill a bat, intentionally or recklessly disturb a bat in its roost or deliberately disturb a group of bats, deliberately damage or destroy a place used by bats for breeding or resting (roosts) (even if bats are not occupying the roost at the time) or intentionally or recklessly obstruct access to a bat roost.

Therefore, bats are to be fully considered before any tree work commences and particularly if trees contain veteran features (which can occur in young trees as well as older trees). This can include all work on trees whether it is surgery, felling, the covering, or filling of cavities or the installation of rod braces and flexible cable braces. If a bat roost is known to be in any tree that is to be removed or worked on, or if any work is to take place adjacent to a known bat roost that may result in disturbance to that bat/s, then a license must be obtained from Natural Resources Wales or Natural England before work can take place.

Where there is the risk of a bat roosts being present, it is incumbent upon the owner or manager to commission a specialist bat survey to identify bat roosts before instructing tree surgery to commence. Failure to do so and in the event of breaching the legislation detailed above is an offence.

Maximum penalties for committing offences relating to bats or their roosts can amount to imprisonment for a term not exceeding six months or to fines of up to Level 5 on the standard scale under the Criminal Justice Act 1982/ 1991 (i.e., £5000 in April 2001) per roost or bat disturbed or killed, or to both.

NOTE - This is a simplified summary of the legal position relating to bats and birds and is intended for guidance purposes only. If further assistance is required, the primary legislation should be referred to. It may also be necessary to see legal advice or the advice of an appropriately qualified ecologist.

In the event of disturbing a roost site or injuring any bats is an offence. Maximum penalties for committing offences relating to bats or their roosts can amount to imprisonment for a term not exceeding six months or to fines of up to Level 5 on the standard scale under the Criminal Justice Act 1982/ 1991 (i.e., £5000 in April 2001) per roost or bat disturbed or killed, or to both.

#### Statute and Common Law – for Tree Inspections.

A landowner or land manager should be aware that both statute and common law dictates regular inspections of trees on land in their control are necessary where such trees could cause injury or damage in the event they should fall or shed any parts. A person suitably qualified in arboriculture should undertake such routine inspections and any remedial tree works recommended should be carried out within the time constraints specified, to prevent injury or damage occurring. A landowner should retain records of all inspections and any remedial tree works that have resulted from such inspections. Arboricultural Association, the Malthouse, Stroud Green, Standish, Stonehouse, Gloucestershire, GL10 3DL. Telephone 01242 522152. [www.trees.org.uk](http://www.trees.org.uk) are able to provide advice on suitably qualified persons or indeed suitable qualifications a person should hold to undertake qualified inspections.

### 9. LIMITATIONS OF THIS REPORT

It must be stressed that this report is a pre-development survey and not a risk assessment or a detailed report on the health and condition of the trees. Whilst any obvious problems noted during this ground level inspection may be noted, general comments are made based on a somewhat cursory, visual inspection. In addition, future management may receive a mention or be briefly discussed but such comments are general comments only, for basic information, which should not be taken to form immediate or long-term management plan, nor do they replace the need for having professional management plans for groups, areas, or woodlands.

Trees are living dynamic organisms which can be affected by external environmental conditions and very occasionally internal biological symptoms that are not visible, causing failure without warning. It is therefore not possible to state with any certainty that any tree is completely safe. There are occasions when even healthy and completely defect-free trees break or become windblown. This represents a "normal failure rate" which is the price of the lightweight, energy-saving structure that favours the species to compete with others in a cost-effective way.

Every attempt has been made to provide a realistic and accurate assessment of trees and their condition at the time of this inspection. No responsibility can be accepted for damage or injury because of the failure of any tree or its parts due to faults not apparent upon a visual inspection carried out at this season, or for faults developing subsequent to the survey. Similarly, no liability can be accepted for the condition of the trees that are obscured in part or by whole (e.g., due to dense ivy or other foliage), nor for any that proved inaccessible to the inspector. Certain features which might provide evidence of ongoing decay or decline (Such as seasonal fruiting bodies, damage to foliage, insect emergence holes etc.) may not be in evidence. Only those features present at the time of inspection could be assessed.

This report is based on the tree's circumstances and condition at the time of the survey. It must be recognised that the circumstances may be altered radically over the course of any development process and that such changes cannot be accurately predicted. The report also does not provide any specific long-term management recommendations.

The effect this new development may have on localised wind turbulence has not been assessed during this inspection. As trees grow, they respond and mechanically adapt to their surroundings and exposure limits. With the erection of dwellings near existing trees, new turbulence is created. The author accepts no liabilities to any failure subsequent upon such new imposed, artificial conditions.

Unless stated in writing, the inspection shall not include any underground parts of the tree. It does not consider **indirect** damage resulting from the extraction of moisture from shrinkable clay soils by tree roots causing **subsidence** or by **heave** occurring through soil rewetting following removal of trees on this site. Such problems are almost entirely restricted to areas of shrinkable clay soils and as I have **not** considered a soil analysis as part of my present brief, this aspect is **not** addressed at this time.

Unless otherwise stated in writing and in the absence of altered circumstances, a report on the health and safety of a tree or trees cannot be relied on after a period of 12 months. Following such a period, a further inspection is required.

Soil testing to ascertain the plasticity index or shrinkable characteristics of the soil on the development site to provide information in relation to the likelihood of building damage caused by tree related subsidence or heave where trees are within influencing distance has not been carried out. The author cannot be held liable for building damage as a result. A soil analysis can be provided if requested.

Further and more general report limitations are set out in the authors Terms and Conditions and copies are available upon request.

## 10. TERMS AND DEFINITIONS

For the purposes of this British Standard, the following terms and definitions apply.

### Access facilitation pruning

One-off tree pruning operation, the nature and effects of which are without significant adverse impact on tree physiology or amenity value, which is directly necessary to provide access for operations on site.

### Arboricultural method statement

Methodology for the implementation of any aspect of development that is within the root protection area (3.7) or has the potential to result in loss of or damage to a tree to be retained.

### Arboriculturist

Person who has, through relevant education, training and experience, gained expertise in the field of trees in relation to construction.

### Competent person

person who has training and experience relevant to the matter being addressed and an understanding of the requirements of the particular task being approached. NOTE A competent person is expected to be able to advise on the best means by which the recommendations of this British Standard may be implemented.

### Construction

Site-based operations with the potential to affect existing trees.

### Construction exclusion zone

Area based on the root protection area from which access is prohibited for the duration of a project.

### Crown Spread

The crown spread is measured as the radius from the centre of the trunk in meters and in most cases is approximate covering the four points of the compass. For woodlands or substantial tree groups, the overall extent of the canopy.

### Diameter (DBH)

The trunk diameter for each tree is measured in millimetres at a height of approximately 1.5 metres above ground level, unless otherwise stated. All measurements are approximate.

### Height

The height of the trees, shrub masses and hedgerows are measured in metres and is usually approximate. If the abbreviation 'Clinom' appears after the given measurement, it indicates the tree has been measured with an optical measuring instrument, a Clinometer, and is accurate to within 5 metres.

### Life Stage

The age of the tree is given based on its life expectancy. For example, an oak tree at an age of 100-years is perceived as early mature when a hawthorn at 100 years would be considered old. Age classes are given as follows: -

- Y. **Young trees** (recently planted or saplings under 15 years old)
- SM. **Semi mature** (around 1/3 their life expectancy, still growing vigorously but not as fast as a younger tree)
- EM **Early Mature** (between 1/3 – 2/3 life expectancy still growing reasonably vigorously)
- M. **Mature trees** (above 2/3 life expectancy. Growth rates beginning to slow down at this stage)
- OM. **Over Mature trees** (growth rates slow and possibly beginning to display signs of decline)
- V. **Veteran** (decline is well set-in, but the tree **may** be of specific ecological value. The tree is likely to contain sufficient deadwood and decay that is a special habitat for many rare invertebrates that are at risk from extinction)

### Number (No.)

A tree number is allocated to each tree or group and provides reference to an individual. It will occur either by way of a T-number T1, T2 etc. or a series of numbers e.g., 00123 that relates to an identification tag attached to the stem of each tree. Such numbers will occur on the Tree Constraints Plan.

### Recommendations

The recommendations give the appropriate action required for the trees or groups of trees to fulfil the brief, which possibly include reducing the most blatant foreseeable risk or improve the physiology of the tree.

### Root protection area (RPA)

Layout design tool indicating the minimum area around a tree deemed to contain sufficient roots and rooting volume to maintain the tree's viability, and where the protection of the roots and soil structure is treated as a priority.

### Service

Any above- or below-ground structure or apparatus required for utility provision.

NOTE Examples include drainage, gas supplies, ground source heat pumps, CCTV and satellite communications.

#### Stem

Principal above-ground structural component(s) of a tree that supports its branches.

#### Special Precaution Area

This is an area, usually within the root protection area, where construction or other activity may be permitted but only under the direction of an 'Arboricultural Method Statement' and the supervision of an Arborist.

#### Species

The species is the given name of the tree which is usually provided in both the common and scientific names.

#### Structure

Manufactured objects, such as a building, carriageway, path, wall, service run, and built or excavated earthwork.

#### Tree Protection Plan

scale drawing, informed by descriptive text where necessary, based upon the finalized proposals, showing trees for retention, and illustrating the tree and landscape protection measures.

#### Veteran Tree

Tree that, by recognized criteria, shows features of biological, cultural, or aesthetic value that are characteristic of, but not exclusive to, individuals surviving beyond the typical age range for the species concerned. NOTE These characteristics might typically include a large girth, signs of crown retrenchment and hollowing of the stem.

#### NOTES.

All measurements given are approximate.

AGL: an abbreviation for above ground level.

REFERENCE. The British Standards Institution 2012

## 11. GLOSSARY OF TERMS

**Adaptive Growth:** in tree biomechanics, the process whereby wood formation is influenced both in quality and in quantity by the action of gravitational force and mechanical stresses on the cambial zone (THIS HELPS TO MAINTAIN A UNIFORM DISTRIBUTION OF MECHANICAL STRESS)

**Adventitious:** Latent or dormant bud on stem or root often invisible until stimulated into growth which occurs from an unusual place i.e., not a twig, leaf or bud.

**Anchorage:** in trees, the holding of the root system within the soil, involving the flow of forces from the stem through the branches of the root system to the cohesive root/soil interface.

**Architecture:** in a tree, a term describing the pattern of branching of the crown or root system.

**Assessment:** in relation to tree hazards, the process of estimating the risk which a tree or group of trees poses to persons or property (THIS INVOLVES A VISUAL INSPECTION FOR DEFECTS AND CONTRIBUTORY SITE FACTORS, AND SOMETIMES ALSO A DETAILED INVESTIGATION OF SUSPECTED DEFECTS)

**Assym:** This abbreviation means...asymmetric...and refers to the tree having an asymmetric or unbalanced crown. This is usually preceded by a measurement in metres which provides the extent of crown asymmetry and is measured from the centre of the trunk. It may also have a correlation to the lever arm.

**Arboriculturalist:** person who has, through relevant education, training, and experience, gained recognised qualifications and expertise in the management of trees generally and in relation to construction.

**Architecture:** in a tree, a term describing the pattern of branching of the crown or root system.

**Arboricultural Implication Assessment (AIA) study,** undertaken by an arboriculturalist, to identify, evaluate and possibly mitigate the extent of direct and indirect impact on existing trees that may arise as a result of the implementation of the site layout.

**Arboricultural Method Statement:** methodology for the implementation of any aspects of development that has the potential to result in loss of or damage to a tree.

**Assessment:** in relation to tree hazards, the process of estimating the risk which a tree or group of trees poses to persons or property (THIS INVOLVES A VISUAL INSPECTION FOR DEFECTS AND CONTRIBUTORY SITE FACTORS, AND SOMETIMES ALSO A DETAILED INVESTIGATION OF SUSPECTED DEFECTS)

**Bole (trunk):** the main stem of a tree below its first major branch

**Branch:** a limb extending from the main stem or parent branch of a tree

**Canopy:** the topmost layer of twigs and foliage in a woodland, tree, or group of trees

**Construction Exclusion Zone:** area based on the RPA (meters as a radial measurement and sometimes a m<sup>2</sup>), identified by an Arboriculturalist, to be protected during development, including demolition and construction work, by use of barriers and/or ground protection fit for the purpose to ensure the successful long-term retention of a tree.

**Crown:** in arboriculture the main foliage-bearing portion of a tree containing the leaves and branches

**Defect:** in relation to tree hazards, any feature of a tree that detracts from the uniform distribution of mechanical stress, or which makes the tree mechanically unsuited to its environment.

**Dysfunction:** in woody tissues, the loss of physiological function, especially water conduction.

**Failure:** in connection with tree hazards, a partial or total fracture within woody tissues or loss of cohesion between roots and soil. (IN TOTAL FAILURE, THE AFFECTED PART SNAPS OR TEARS AWAY COMPLETELY. IN PARTIAL FAILURE, THERE IS A CRACK OR DEFORMATION WHICH RESULTS IN AN ALTERED DISTRIBUTION OF MECHANICAL STRESS)

**Group:** the term 'group' is intended to identify trees that form cohesive arboricultural features either **aerodynamically** (e.g., trees that provide companion shelter), **visually** (e.g., avenues or screens) or **culturally** including for biodiversity (e.g., parkland or wood pasture).

**Heave:** in relation to a shrinkable clay soil, expansion due to re-wetting, sometimes after the felling or root severance of a tree which was previously extracting moisture from the deeper layers: also, in relation to root growth, the lifting of pavements and other structures by radial expansion: also, in relation to tree stability, the lifting of one side of a wind-rocked root plate.

**Leader:** in a tree, a topmost shoot that has apical dominance.

**Preventive action:** in a tree hazard management, action that helps to prevent injury to persons or damage to property.

**Pruning:** the removal or cutting back of twigs, branches or roots: in some contexts, applying only to twigs or small branches only, but more often used to describe all kinds of work involving cutting.

**Retained Tree:** a tree that has been considered suitable by an Arborist for retention and which during the design stage is selected for retention and incorporated within the development.

**Risk:** the likelihood of the potential harm from a particular hazard becoming actual harm.

**Root Protection Area (RPA):** layout design tool indicating the area surrounding a tree that contains sufficient rooting volume to ensure the survival of the tree, shown in plan form in m<sup>2</sup>.

**Soil heave:** see heave.

**Subsidence:** in relation to soil or structures resting in or on soil, a sinking due to shrinkage when clay soils dry out, sometimes due to extraction of moisture by tree roots.

**Subsidence:** in relation to branches of trees, a term that can be used to describe a progressive downward bending due to increasing weight.

**Targets:** in a tree hazard assessment (and with somewhat incorrect terminology), persons or property or other things of value, which might be harmed by mechanical failure of the tree or by objects falling from it.

**Tree:** a woody plant, which typically has a single main stem and, in maturity, attains a height of at least four metres and a stem diameter at breast height of at least 75-mm.

**Tree Constraint Plan (TCP):** plan prepared by an Arboriculturalist for the purpose of layout design showing the RPA and representing the effect that the mature height and spread of retained trees will have on layouts through shade dominance, etc.

**Tree Preservation Order:** in Great Britain, an order made by a local authority, whereby the authority's consent is generally required for the cutting down, topping or lopping of specified trees.

**Tree Protection Plan:** scale drawing prepared by an arboriculturalist showing the final layout proposals, tree retention and tree and landscape protection measures detailed within the arboricultural method statement (AMS), which can be shown graphically.

**Trunk:** the single main stem of a tree.

**Vigour:** in tree assessment, an overall measure of the rate of shoot production, shoot extension or diameter growth (*cf.* vitality)

**Visual Tree Assessment (VTA):** in addition to the literal meaning, a system expounded by Mattheck & Breloer (1995) to aid the diagnosis of potential defects through visual signs and the application of mechanical criteria.

**Wind exposure:** the degree to which a tree or other object is exposed to wind, with regard both to duration and velocity.

**Wind pressure:** the force exerted by wind on a tree or other object.

**Wind snap:** the breaking of a tree stem by wind.

**Windthrow:** the blowing over of a tree at its roots.

## 12. REFERENCES

- o **British Standard Recommendations for Tree Work BS 3998: 2010**
- o **British Standard 5837: 2012** Trees in Relation to Design, Demolition and Construction - Recommendations
- o **Guidance Note 10, Protected Species and Arboriculture** (Arboricultural Association)
- o **Fay N, Dowson D, Heliwell R.** Tree Surveys, A Guide to Good Practice (Arboricultural Association)
- o **Lonsdale D.** Principles of Tree Hazard Assessment and Management. (Department of the Environment, Transport and Regions)
- o **Mattheck C. & Breloer H.** The Body Language of Trees (Department of the Environment).
- o **Hillier Manual of Trees and Shrubs**
- o **Lonsdale D.** Hazards from Trees, A General Guide, Forestry Practice Guide
- o **Find the Elevation on a Map** (daftlogic.com)
- o **Soilscapes soil types viewer - National Soil Resources Institute.** Cranfield University (landis.org.uk)
- o **Streetmap - Maps and directions for the whole of Great Britain**
- o **what3words ///** The simplest way to talk about location

### 13. APPENDICES

APPENDIX A - TABLE 1 TREE QUALITY ASSESSMENT

APPENDIX B - DEFAULT SPECIFICATION FOR PROTECTIVE BARRIER

APPENDIX C - TABLE B1- TREES AND THE PLANNING SYSTEM

APPENDIX D – PHOTOGRAPHS

APPENDIX E – BASE LINE DATA CAPTURE

APPENDIX F – SITE LOCATION PLAN

APPENDIX G - TREE CONSTRAINTS PLAN

## APPENDIX A - TABLE 1 TREE QUALITY ASSESSMENT

The trees are categorised as stated within the British Standard in a way that should help assist those within local government to help form a balanced judgement. The primary purpose of this report is to provide an assessment of the trees and to determine their suitability for retention in any proposed development.

The Tree Categories used in evaluating the trees on this site are reproduced below. This categorisation is also included in the tree data schedules and by colour code on the attached plan.

Category and definition Criteria (including subcategories where appropriate)

### Category U

Trees unsuitable for retention (see Note)

Those in such a condition that they cannot realistically be retained as living trees in the context of the current land use for longer than 10 years

- ✓ Trees that have a serious, irremediable, structural defect, such that their early loss is expected due to collapse, including those that will become unviable after removal of other category U trees (e.g., where, for whatever reason, the loss of companion shelter cannot be mitigated by pruning)
- ✓ Trees that are dead or are showing signs of significant, immediate, and irreversible overall decline
- ✓ Trees infected with pathogens of significance to the health and/or safety of other trees nearby, or very low-quality trees suppressing adjacent trees of better quality

**NOTE** - Category U trees can have existing or potential conservation value which it might be desirable to preserve: Refer to 4.5.7. See Table 2

Trees to be considered for retention

### Category A

Trees of high quality with an estimated remaining life expectancy of at least 40 years

- ✓ 1 Mainly arboricultural qualities- Trees that are particularly good examples of their species, especially if rare or unusual: or those that are essential components of groups or formal or semi-formal arboricultural features (e.g., the dominant and/or principal trees within an avenue)
- ✓ 2 Mainly landscape qualities- Trees, groups or woodlands of particular visual importance as arboricultural and/or landscape features
- ✓ 3 Mainly cultural values, including conservation- Trees, groups or woodlands of significant conservation, historical, commemorative or other value (e.g., veteran trees or wood-pasture) See Table 2

### Category B

Trees of moderate quality with an estimated remaining life expectancy of at least 20 years.

- ✓ 1 Mainly arboricultural qualities- Trees that might be included in category A, but are downgraded because of impaired condition (e.g., presence of significant though remediable defects, including unsympathetic past management and storm damage), such that they are unlikely to be suitable for

retention for beyond 40 years: or trees lacking the special quality necessary to merit the category A designation

- ✓ 2 Mainly landscape qualities- Trees present in numbers, usually growing as groups or woodlands, such that they attract a higher collective rating than they might as individuals: or trees occurring as collectives but situated so as to make little visual contribution to the wider locality
- ✓ 3 Mainly cultural values, including conservation- Trees with material conservation or other cultural value See Table 2

### Category C

Trees of low quality with an estimated remaining life expectancy of at least 10 years, or young trees with a stem diameter below 150 mm.

- ✓ 1 Mainly arboricultural qualities- Unremarkable trees of very limited merit or such impaired condition that they do not qualify in higher categories
- ✓ 2 Mainly landscape qualities- Trees present in groups or woodlands, but without this conferring on them significantly greater collective landscape value: and/or trees offering low or only temporary/transient landscape benefits.
- ✓ 3 Mainly cultural values, including conservation- Trees with no material conservation or other cultural value. See Table 2.

**NOTE** - The British Standard states...*Particular care is needed when evaluating young trees, especially where they occur as individual specimens. Where these are less than 150 mm stem diameter at 1.5 m above adjacent ground level, it might be acceptable and relatively straightforward to mitigate their loss, if necessary, with similar new tree planting. Alternatively, it might be practicable to relocate such trees within the site (e.g., using a tree spade). Whilst the presence of young trees of good form and vitality is generally desirable (i.e. those trees which have the potential to develop into quality mature specimens), they need not necessarily be a significant constraint on the site's potential.*

Where remaining contributory years' score is provided within the 'Findings' , and where further investigative works are required, these scores are preliminary only and based on an incomplete inspection.

### BRITISH STANDARD BS 5837:2012

© The British Standards Institution (BSI) 2012 • 9

The extracts used within this Report are purchased from the BSI by Steve Ambler & Sons Arboricultural Consultancy & Tree Specialists

**APPENDIX B - DEFAULT SPECIFICATION FOR PROTECTIVE BARRIER**

Figure 2 Default specification for protective barrier

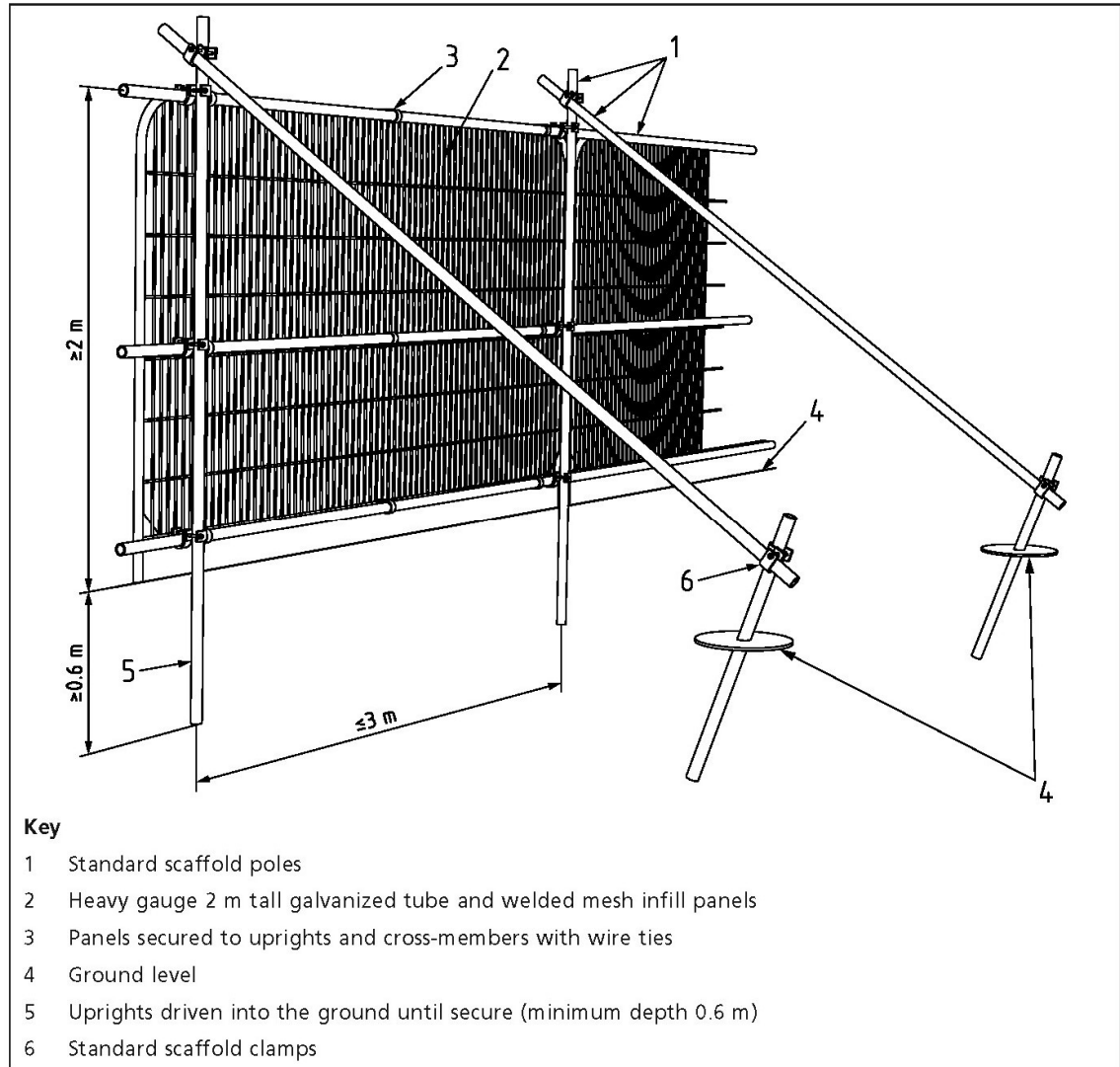
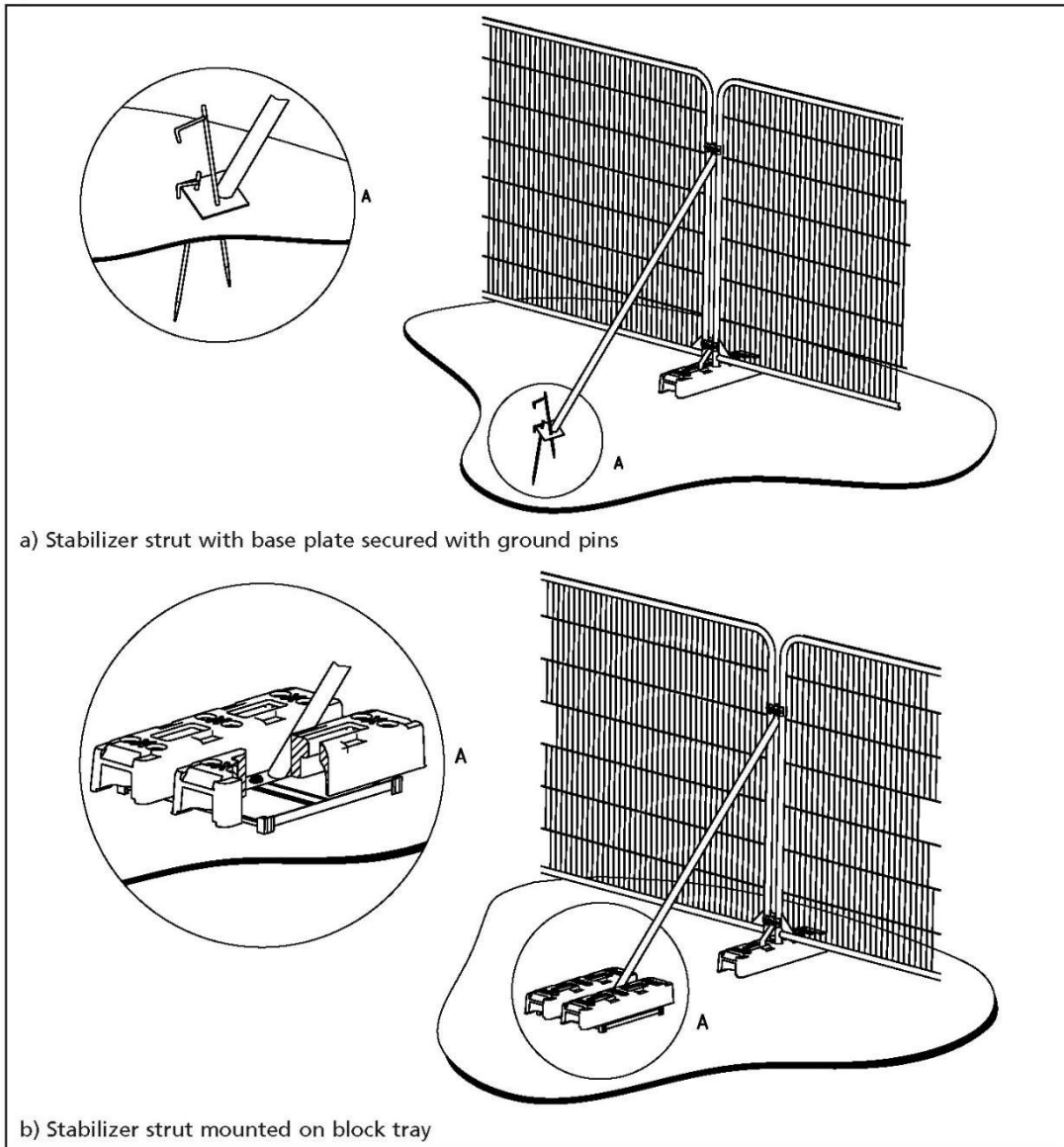

Figure 3 Examples of above-ground stabilizing systems



**APPENDIX C - TABLE B1- TREES AND THE PLANNING SYSTEM**

**BS 5837:2012**

**BRITISH STANDARD**

**Annex B  
(informative)**

**Trees and the planning system**

Under the UK planning system, local authorities have a statutory duty to consider the protection and planting of trees when granting planning permission for proposed development. The potential effect of development on trees, whether statutorily protected (e.g. by a tree preservation order or by their inclusion within a conservation area) or not, is a material consideration that is taken into account in dealing with planning applications. Where trees are statutorily protected, it is important to contact the local planning authority and follow the appropriate procedures before undertaking any works that might affect the protected trees.

The nature and level of detail of information required to enable a local planning authority to properly consider the implications and effects of development proposals varies between stages and in relation to what is proposed. Table B.1 provides advice to both developers and local authorities on an appropriate amount of information. The term "minimum detail" is intended to reflect information that local authorities are expected to seek, whilst the term "additional information" identifies further details that might reasonably be sought, especially where any construction is proposed within the RPA.

**Table B.1 Delivery of tree-related information into the planning system**

<b>Stage of process</b>	<b>Minimum detail</b>	<b>Additional information</b>
Pre-application	Tree survey	Tree retention/removal plan (draft)
Planning application	Tree survey (in the absence of pre-application discussions) Tree retention/removal plan (finalized) Retained trees and RPAs shown on proposed layout Strategic hard and soft landscape design, including species and location of new tree planting Arboricultural impact assessment	Existing and proposed finished levels Tree protection plan Arboricultural method statement – heads of terms Details for all special engineering within the RPA and other relevant construction details
Reserved matters/ planning conditions	Alignment of utility apparatus (including drainage), where outside the RPA or where installed using a trenchless method Dimensioned tree protection plan Arboricultural method statement – detailed Schedule of works to retained trees, e.g. access facilitation pruning Detailed hard and soft landscape design	Arboricultural site monitoring schedule Tree and landscape management plan Post-construction remedial works Landscape maintenance schedule

## APPENDIX D - PHOTOGRAPHS

Photograph 1: G1- Ivy clad stems restrict inspection.



Photograph 2: G7- Goat willow with 75% crown dieback.



Photograph 3: H1- dead elm trees within falling distance of the site boundary.



**Photograph 4:** T2 ivy clad stem restricts inspection of the base.



Photograph 5: T2 crown dieback on the eastern southeastern side towards the rugby fields.



Photograph 6: T6 soil compaction observed due to vehicle parking.



Photograph 7: T24 raised kerb stones due to root growth beneath the paved areas.



**Photograph 8:** T26- part of a row of trees that have been pollarded in the last several years.



**Photograph 9:** T28 limited rooting area amongst hard surfacing, with evidence of root growth beneath the paving slabs.



**Photograph 10:** T32 dense ivy obscures the inspection of the main stem.



## APPENDIX E – BASE LINE DATA CAPTURE

The following baseline data for each tree, group of trees or woodland have been recorded in the Table of Findings & Section 3.

Prefix – Tree (T), Group (G), Hedge (H), Woodland (W).

Species including the common and scientific names.

Height measured in metres from the stem base. Where the ground has a significant slope, measurements are taken from the higher ground.

Crown height within groups is measured in metres as an indication of average height where the main crown is formed.

Stem diameter is measured in millimetres at 1.5-m above ground level. Where the ground has a significant slope measurements are taken from the higher ground or immediately above the root flare for multi-stemmed trees.

Crown spread is measured in metres at the four cardinal points to accurately represent the crown.

Age class is described as young, semi-mature, early-mature, mature or over-mature.

Physiological condition as applicable is classed as good, fair, poor, or dead. This is an indication of the health of the tree and considers vigour, presence of disease and dieback.

Structural condition as applicable is classed as good, fair or poor. This is an indication of the structural integrity of the tree and takes into account significant wounds, decay and quality of branch junctions.

Life expectancy is classed as: less than 10 years (<10) (Very Short): 10-20 years (Short): 20-40 years (Medium): or more than 40 years (40+) (Long). This is an indication of the safe useful life expectancy and number of years before removal is likely.

General Observations may include a brief description to include the visual merits of the tree/s, other beneficial characteristics, form, vitality, health and any visually obvious significant defects that may be present.

Recommendations are given in order to offset risks posed by identified hazards, management to improve the amenity value / habitat value / life expectancy.

**APPENDIX F – SITE LOCATION PLAN**

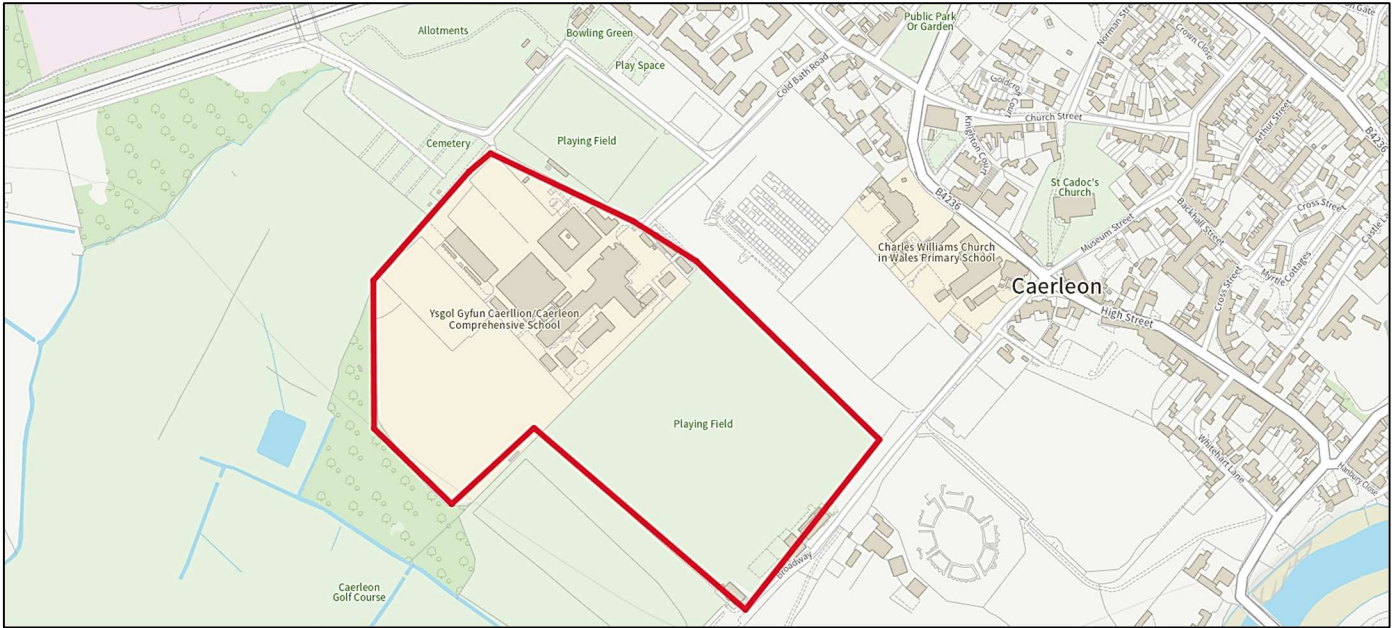

## APPENDIX G – TREE CONSTRAINTS PLAN



Ref	Tree Tag	Species	Height (m)	Effectual Diameter (mm)	Remaining Contribution (Years)	Retention Category	Root Protection Area (M2)	Root Protection Radius (M radius)
G1	N/A	Common lime	22	500	20-40	B2	113.1	6.0
G2	N/A	Sycamore Rowan Silver maple	18	500	20-40	B2	113.1	6.0
G3	N/A	Swedish whitebeam London plane Common ash Broad-leaved lime Norway maple Field maple	15	450	20-40	B2	91.6	5.4
G4	N/A	Swedish whitebeam Sycamore Field maple	10	100	20-40	C2	4.5	1.2
G5	N/A	European larch	13	320	20-40	C2	46.3	3.8
G6	N/A	Hazel	8	120	20-40	C2	6.5	1.4
G7	N/A	Common alder Silver birch	16	350	20-40	B2	55.4	4.2
G8	N/A	European lime	18	500	20-40	B2	113.1	6.0
G9	N/A	Broad-leaved lime	20	450	20-40	B2	91.6	5.4
G10	N/A	Swedish whitebeam Pedunculate oak Norway maple Common ash Horse chestnut	18	450	20-40	B2	91.6	5.4
G11	N/A	Common ash	17	500	<10	U	0.0	0.0
G12	N/A	Sycamore Common ash	18	450	20-40	B2	91.6	5.4
G13	N/A	Swedish whitebeam Field maple Elder	16	450	20-40	B2	91.6	5.4
H1	N/A	Common hawthorn	7	120	20-40	B2	6.5	1.4
T1	N/A	Whitebeam	14	400	20-40	B2	72.4	4.8
T2	N/A	Sycamore	20	500	10-20	C2	113.1	6.0
T3	N/A	Whitebeam	14	400	20-40	B2	72.4	4.8
T4	N/A	Sycamore	18	450	20-40	B2	91.6	5.4
T5	1782	Silver birch	15	280	20-40	B2	35.5	3.4
T6	1783	Silver birch	15	400	20-40	B2	72.4	4.8
T7	1784	Silver birch	15	360	20-40	B2	58.6	4.3
T8	1785	Silver birch	15	270	20-40	B2	33.0	3.2
T9	N/A	Bay tree	7	80	20-40	C2	2.9	1.0
T10	N/A	Grey alder	10	170	20-40	C2	13.1	2.0
T11	N/A	Bay tree	7	80	20-40	C2	2.9	1.0
T12	N/A	Grey alder	10	170	20-40	C2	13.1	2.0
T13	N/A	Grey alder	10	170	20-40	C2	13.1	2.0
T14	N/A	Rowan	7	80	20-40	C2	2.9	1.0
T15	N/A	Wych elm	8	120	<10	U	0.0	0.0
T16	1786	Austrian pine	10	240	20-40	B2	26.1	2.9
T17	1787	Austrian pine	10	220	20-40	B2	21.9	2.6
T18	N/A	Elder	3	80	<10	U	0.0	0.0
T19	1788	Bird cherry	7	170	10-20	C2	13.1	2.0
T20	2808	Wild cherry	15	350	20-40	B2	55.4	4.2
T21	N/A	Rowan	8	150	20-40	C2	10.2	1.8
T22	1789	Common alder	15	340	20-40	B2	52.3	4.1
T23	1790	Norway maple	9	190	20-40	B2	16.3	2.3
T24	2791	Broad-leaved lime	15	410	20-40	C2	76.0	4.9
T25	1779	Broad-leaved lime	15	410	20-40	C2	76.0	4.9
T26	2792	Broad-leaved lime	15	610	20-40	C2	168.3	7.3
T27	2793	Broad-leaved lime	15	410	20-40	C2	76.0	4.9
T28	2794	Broad-leaved lime	15	470	20-40	C2	99.9	5.6
T29	2795	Broad-leaved lime	15	480	20-40	C2	104.2	5.8
T30	1796	Wild cherry	12	320	20-40	B2	46.3	3.8
T31	N/A	Cotoneaster	4	90	20-40	C2	3.7	1.1
T32	2802	Weeping willow	20	880	20-40	B2	350.3	##
T33	140	Plum	4	130	40+	C2	7.6	1.6
T34	N/A	Cultivar apple	3	100	40+	C2	4.5	1.2
T35	N/A	Cultivar apple	3	160	40+	B2	11.6	1.9
T36	N/A	Cultivar apple	5	130	40+	C2	7.6	1.6
T37	N/A	Cockspur hawthorn	5	100	40+	C2	4.5	1.2
T38	1798	Willow-leaved pear	10	370	20-40	B2	61.9	4.4
T39	1799	Snowy mespilus	7	120	20-40	B2	6.5	1.4
T40	N/A	Sycamore	14	350	20-40	B2	55.4	4.2
T41	N/A	Wild cherry	7	20	20-40	C2	0.2	0.2
T42	N/A	Sweet gum	8	200	20-40	C2	18.1	2.4
T43	N/A	Wild cherry	8	250	10-20	C2	28.3	3.0
T44	N/A	Wild cherry	8	250	10-20	C2	28.3	3.0
W1	N/A	Wild cherry Aspen Pedunculate oak Common hawthorn Red oak Common ash Horse chestnut Rowan Sycamore	17	500	40+	B2	113.1	6.0

(Please check all RPA's on site.)

### Key

Trees to be considered for retention.

- A - High
- B - Moderate
- C - Low
- Root Protection Area

Trees unsuitable for retention.

- U - Fell

### Tree Key

Crown Spread. Measured in North, South, East and West side of tree.

T1 Tree number. (T - Individual Tree, G - Group, A - Tree area, W - Woodland, H - Hedgerow)

**Root Protection Area (RPA)**  
A layout design tool indicating the minimum area around a tree deemed to contain sufficient roots and rooting volume to maintain the tree's viability, and where the protection of the roots and soil structure is treated as a priority.

This plan should be read in conjunction with the Caerleon Comprehensive School Tree Survey & Categorisation Report June 2024 (Ambler SJ.)

The original of this drawing was produced in colour. A monochrome copy should not be relied upon.

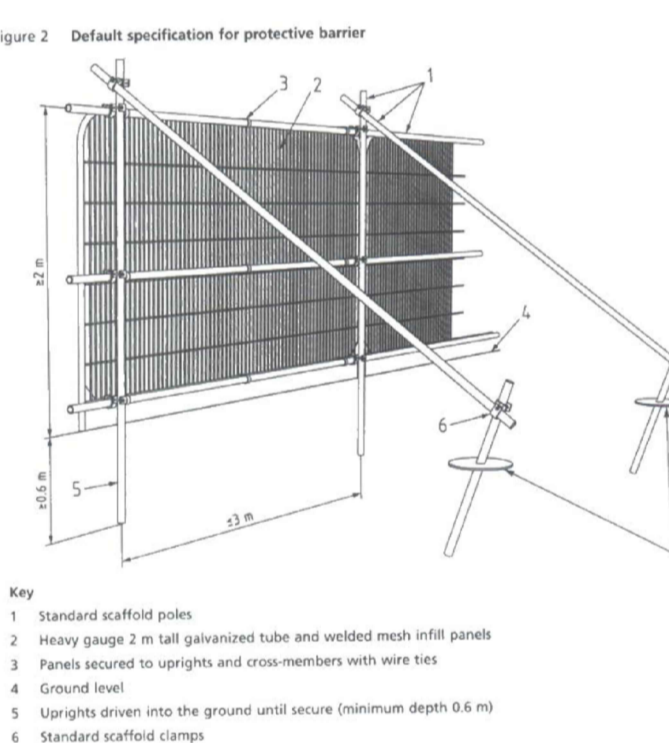

Steve Ambler & Sons Tree Specialists Ltd  
Tec.Arbor.A., Dip.Arb.(RFS), F.ARBOR.A.

Client	Newport Norse
Surveyed by	SJA
Date surveyed	June 2024
Drawn by	BC
Scale	1:900 when printed at A1
OS Grid Ref	ST 33566.92 90552.70

INDICATIVE ONLY. PLEASE REFER TO ROOT PROTECTION TABLE. DO NOT SCALE FROM THIS DRAWING. CHECK ALL DIMENSIONS ON SITE.

REF. DRAWINGS	Caerleon Comprehensive School Topographical Survey
ASP1797-1	

TITLE  
**Tree Constraints Plan  
Caerleon Comprehensive School**

DRAWING No: **24-043**